

LD220

DUAL LOOP DETECTOR WITH MODBUS COMMUNICATIONS



USER MANUAL



P.O.Box 24
STANFIELD 3613
SOUTH AFRICA

Tel: +27 (031) 7028033
Fax: +27 (031) 7028041
Email: proconel@proconel.com
Web: www.proconel.com

TABLE OF CONTENTS

1.	AN OVERVIEW OF THE LD220 MODBUS SYSTEM	3
2.	LD220 HARDWARE	5
2.1	SPECIFICATIONS	5
2.2	WIRING.....	6
3.	DIAGNOSTICS	7
4.	RELAY FUNCTIONALITY	8
5.	LOOP INSTALLATION GUIDE	8
6.	DATA ADDRESSES.....	9
6.1	LD220 - DUAL CHANNEL DETECTOR (MODULE TYPE = 35).....	10

1. AN OVERVIEW OF THE LD220 MODBUS SYSTEM

The LD220 is a series of dual channel inductive loop detectors. The use of microprocessor and surface mount technology enables a large number of functions to be incorporated into a small package. The LD220 is compatible with most dual channel detectors on the market and is easy to set-up and install. All configuration is done through the communications port.

The LD220 is supplied with a RS485 communications port. The LD220R is supplied with a RS232 communications port.

Typical applications in the parking and access control environments are safety loops, arming loops and entry or exit loops and direction logic with counting.

The LD220 consists of an inductive loop detector with an integral RS485 communications port. The unit has been developed to enable remote monitoring and control of the loop detector over a RS485 network. The communications allows access to internal setup parameters such as sensitivity, timers, as well as counters. The LD220 can be multi-dropped on the RS485 network with other detectors and logic units, or linked to a PC running software for configuration and monitoring of the parking system. Non volatile memory is used to store counters and all configuration parameters.

Standard features of the logic on the unit are :

- **RS485 Communications Port.**

The RS485 communications port enables up to 127 detectors to be networked on a single twisted pair cable. The LD220 communicates using the Modbus protocol in Binary mode. All configuration data is held in modbus registers and can be setup by a PC or PLC on the network.

- **Selectable Pulse Time.**

This feature sets the length of time that the pulse relay will be energized.

- **Pulse Relay Selection.**

The Pulse relay may be configured to energize on detection of a vehicle or when the vehicle leaves the loop.

- **Sensitivity Boost.**

This feature sets the undetect level to maximum sensitivity and is used to prevent loss of detection of high-bed vehicles.

- **Switch selectable Sensitivity.**

The detect sensitivity is the minimum change in inductance required to produce a detect output. ($\% \Delta L/L$).

- **Switch selectable Frequency.**

The frequency of the loop is determined by the inductance of the loop and the frequency switch setting. If the frequency switch is on, the frequency is reduced. It may be necessary to change the frequency to prevent cross-talk between adjacent loops.

- **Filter Option.**

This option is used to provide a delay between detection of the vehicle and switching of the output relay. This delay is normally used to prevent false detection of small or fast moving objects.

- **Direction Logic.**

This feature enables the detector to give a pulse output on relay1 for a vehicle traveling from loop1 to loop2 and a pulse output on relay2 for a vehicle traveling from loop2 to loop1.

- **Loop Fault Indicator.**

This LED Indicator is illuminated when the loop is either open circuit or short circuit and is used to give a visual indication of a faulty loop.

- **Power Indicator.**

This LED Indicator illuminates when power is present.

- **Detect Indicator.**

This LED Indicator is illuminated when there is a vehicle over the loop or the loop is faulty. This LED can also be used to determine the loop frequency. On reset, count the number of times the LED flashes. Multiply this number by 10KHz. For example: if the LED flashes 6 times, then the loop frequency is between 60KHz and 70KHz.

- **Network Layout.**

The diagram below shows how the LD220 may be connected to a Modbus network. The LD220 can be placed on the network with other I/O products such as the popular **MOD-MUX** from Procon Electronics.

A typical application is where a **PC** (Personal Computer) is connected to the Network. Many SCADA software packages support the MODBUS Master Protocol and can hence retrieve data from the LD220 as well as Input Modules or send data to Output Modules. The **serial port** of the PC is connected to an **RS232/RS485 Converter** which in turn is connected to the Network.

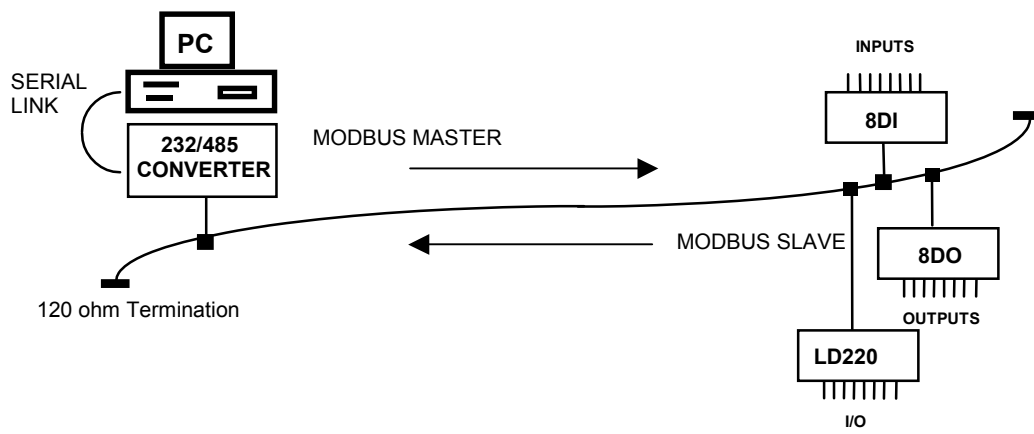

2. LD220 HARDWARE

2.1 SPECIFICATIONS

POWER REQUIREMENT:

LD220 - 220VAC (+/- 15%) 50Hz.

LD221 - 110VAC (+/- 15%) 60Hz.

LD222 - 12/24VAC/DC (+/- 15%).

RELAY OUTPUT: These outputs has are either a normally open or normally closed relay contact rated at 0.5A/220VAC.(select with internal jumper)

INDICATORS: LED indicator's show: Power, Detect state and Loop Fault.

DETECTOR TUNING RANGE: 15 - 1500 uH.

FREQUENCY: Single step adjustable (internal jumper).

PROTECTION: Loop isolation transformer with lightening protection.

CONNECTOR: 11 Pin Connector on rear of unit.

DIMENSIONS: 80mm (HIGH) X 40mm (WIDE) X 79mm (DEEP)

OPERATING TEMPERATURE: -40°C to +80°C

STORAGE TEMPERATURE: -40°C to +85°C

HUMIDITY: up to 95% non condensing

Complies with EMC Directive 89/336/EEC and Low Voltage Equipment Directive 73/23/EEC.

2.2 WIRING

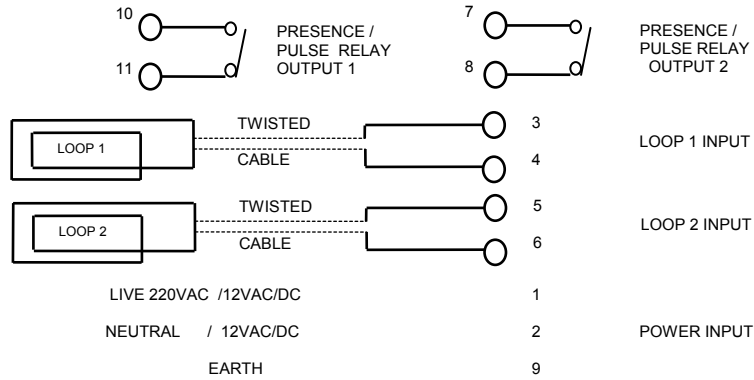

Comms (RJ45) – RS485 (LD220)

Pin	Name	Function
1	N/C	Not used (no connect)
2	485	+ Line of 485 Comms
3	485	- Line of 485 Comms
4	N/C	Not used (no connect)

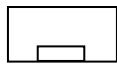

1 2 3 4

View From Cable side of connector (Looking 'into' hole)

Comms (RJ45) – RS232 (LD220R)

Pin	Name	Function
1	N/C	Not used (no connect)
2	TXD	RS232 Transmit
3	RXD	RS232 Receive
4	GND	RS232 Common

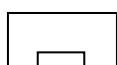

1 2 3 4

View From Cable side of connector (Looking 'into' hole)

3. DIAGNOSTICS

SYMPTOM	POSSIBLE CAUSE	SOLUTION
The POWER LED is not on.	No power supply voltage on the input.	Check that the power supply is correctly wired to the detector. (PINS 1 and 2)
The DETECT LED flashes erratically.	There may be a poor connection in the loop or loop feeder. The detector may be experiencing crosstalk with the loop of an adjacent detector.	Check all wiring. Tighten screw terminals. Check for broken wires. Try changing frequencies using the frequency switch. Put the detector with the larger loop onto low frequency and the detector with the smaller loop onto high frequency.
The DETECT LED randomly stays on.	Faulty loop or loop feeder wiring. Movement of the loop in the ground.	Check the wiring. Tighten screw terminals. Check for pinched or bent wires. Is the feeder wire twisted? Check for cracks in the road surface near the loop.
The LOOP FAULT LED is flashing.	The loop inductance is too small or the loop is short circuit.	Check that there is no short circuit on the loop feeder wiring or the loop. If there is no short circuit then the inductance is too small and more turns of wire should be added to the loop.
The LOOP FAULT LED is permanently illuminated.	The loop inductance is too large or the loop is open circuit.	Check that there is electrical continuity on the loop. This can be done using a multimeter on the ohms range ($< 5 \Omega$). If the loop inductance is too large then try reducing the number of turns.

4. RELAY FUNCTIONALITY

RELAYS		VEHICLE PRESENT	NO VEHICLE	LOOP FAULTY	NO POWER
PRESENCE RELAY	N/O	CLOSED	OPEN	CLOSED	CLOSED
	N/C	OPEN	CLOSED	OPEN	OPEN
PULSE RELAY	N/O	PULSE CLOSED	OPEN	CLOSED	CLOSED
	N/C	PULSE OPEN	CLOSED	OPEN	OPEN

5. LOOP INSTALLATION GUIDE

1. The detector should be installed in a waterproof housing as close to the loop as possible.
2. The loop and feeder should be made from insulated copper wire with a minimum cross-sectional area of 1.5mm^2 . The feeder should be twisted with at least 20 turns per metre. Joints in the wire are not recommended and must be soldered and made waterproof. Faulty joints could lead to incorrect operation of the detector. Feeders which may pick up electrical noise should use screened cable, with the screen earthed at the detector.
3. The loop should be either square or rectangular in shape with a minimum distance of 1 metre between opposite sides. Normally 3 turns of wire are used in the loop. Large loops with a circumference of greater than 10 metres should use 2 turns while small loops with a circumference of less than 6 metres should use 4 turns. When two loops are used in close proximity to each other it is recommended that 3 turns are used in one and 4 turns in the other to prevent cross-talk.
4. Cross-talk is a term used to describe the interference between two adjacent loops. To avoid incorrect operation of the detector, the loops should be at least 2 metres apart and on different frequency settings.
5. For loop installation, slots should be cut in the road using a masonry cutting tool. A 45° cut should be made across the corners to prevent damage to the wire on the corners. The slot should be about 4mm wide and 30mm to 50mm deep. Remember to extend the slot from one of the corners to the road-side to accommodate the feeder.
6. Best results are obtained when a single length of wire is used with no joints. This may be achieved by running the wire from the detector to the loop, around the loop for 3 turns and then back to the detector. The feeder portion of the wire is then twisted. Remember that twisting the feeder will shorten its length, so ensure a long enough feeder wire is used.
7. After the loop and feeder wires have been placed in the slot, the slot is filled with an epoxy compound or bitumen filler.

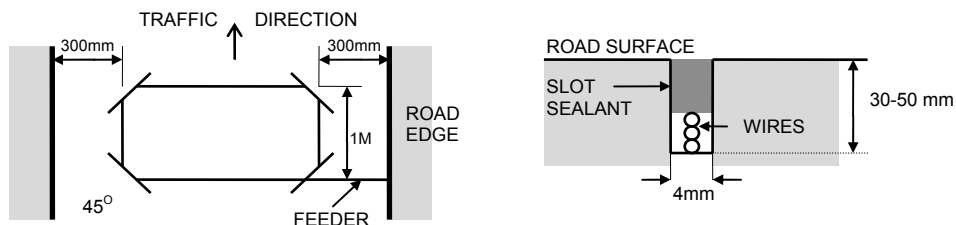

6. DATA ADDRESSES

The data in the modules is stored in registers. These registers are accessed over the network using the MODBUS communication protocol.

The MODBUS mode used is the **RTU** mode with the following set-up:

BAUD RATE	9600
DATA BITS	8
PARITY	NONE
STOP BITS	1

There are 4 types of variables which can be accessed from the module. Each module has one or more of these data variables.

<u>Type</u>	<u>Start Address</u>	<u>Variable</u>
1	00001	Digital Outputs
2	10001	Digital Inputs
3	30001	Input registers (Analog)
4	40001	Output registers (Analog)

Note: Due to the limited buffer memory size in the modules, the Modbus message length must be limited to 8 consecutive read or write registers. If more registers are required then a new poll group must be added for the next 8 registers.

6.1 LD220 - Dual Channel Detector (MODULE TYPE = 35)

Modbus Address	Register Name	Low Limit	High Limit	Access	Comments
10001	Digital Input 1	0	1	R	Loop1 Fault Status.
10002	Digital Input 2	0	1	R	Loop1 Detect Status.
10003	Digital Input 3	0	1	R	Loop2 Fault Status.
10004	Digital Input 4	0	1	R	Loop2 Detect Status.
10005	Digital Input 5	0	1	R	Loop1 Error – Open circuit.
10006	Digital Input 6	0	1	R	Loop1 Error – Short circuit.
10007	Digital Input 7	0	1	R	Loop2 Error – Open circuit.
10008	Digital Input 8	0	1	R	Loop2 Error – Short circuit.
00009	Digital Output 1	0	1	R/W	Relay 1
00010	Digital Output 2	0	1	R/W	Relay 2
30001	S/W Version / Module Type	N/A	N/A	R	High Byte = Software Version Low Byte = 35
30002	Digital I/O	N/A	N/A	R	0, bit 15 0, bit 14 0, bit 13 0, bit 12 0, bit 11 0, bit 10 Relay 2 bit 9 Relay 1 bit 8 Loop2 Error – Short circuit bit 7 Loop2 Error – Open circuit bit 6 Loop1 Error – Short circuit bit 5 Loop1 Error – Open circuit bit 4 Loop2 Detect Status bit 3 Loop2 Fault Status bit 2 Loop1 Detect Status bit 1 Loop1 Fault Status bit 0
40003	Seconds	0	65535	R/W	Real Time Clock
40004	Minutes	0	65535	R/W	"
40005	Hours	0	65535	R/W	"
40006	Days	0	65535	R/W	"
40007	Date	0	65535	R/W	"
40008	Month	0	65535	R/W	"
40009	Year	0	65535	R/W	"
40010	Counter 1 LSB	0	65535	R/W	Counter MSB and LSB combine to give a 32 bit
40011	Counter 1 MSB	0	65535	R/W	Counter with range 0 to 4294967295.

40012	Counter 2 LSB	0	65535	R/W	"
40013	Counter 2 MSB	0	65535	R/W	"
40014	Node ID	0	65535	R/W	Network ID (default = 254)
40015	Mode	0	65535	R/W	0, bit 7 0, bit 6 pulse relay2 (1=undetected,0=detected) bit 5 pulse relay1 (1=undetected,0=detected) bit 4 relay2 (1=pulse,0=presence) bit 3 relay1 (1= pulse,0=presence) bit 2 pres relay (1=modbus,0=detector) bit 1 direction logic (1=on,0=off) bit 0
40016	Det Sensitivity 1	0	65535	R/W	(X0.01%)
40017	Det Sensitivity 2	0	65535	R/W	(X0.01%)
40018	UnDet Sens 1	0	65535	R/W	(X0.01%)
40019	UnDet Sens 2	0	65535	R/W	(X0.01%)
40020	Pulse Time 1	0	65535	R/W	(X10ms)
40021	Pulse Time 2	0	65535	R/W	(X10ms)
40022	Filter 1	0	65535	R/W	(X10ms)
40023	Filter 2	0	65535	R/W	(X10ms)
40024	UnDet Time 1	0	65535	R/W	(X10ms)
40025	UnDet Time 2	0	65535	R/W	(X10ms)
40026	Reset Seconds	0	65535	R/W	
40027	Reset Minutes	0	65535	R/W	
40028	Reset Hours	0	65535	R/W	
40029	Reset Days	0	65535	R/W	
40030	Reset Date	0	65535	R/W	
40031	Reset Month	0	65535	R/W	
40032	Reset Year	0	65535	R/W	
40033	Reset Counter	0	65535	R/W	
40034	Pwr_Down Cntr	0	65535	R/W	
40035	Re-Tune Cntr 1	0	65535	R/W	
40036	Re-Tune Cntr 2	0	65535	R/W	
40037	Not Used	0	65535	R/W	
40038	Loop1Freq.MS B	0	65535	R/W	Frequency MSB and LSB combine to give a 32
40039	Loop1Freq. LSB	0	65535	R/W	bit value.
40040	Loop2Freq.MS B	0	65535	R/W	"
40041	Loop2Freq. LSB	0	65535	R/W	"
40042	Delta 1	0	65535	R/W	Change in loop inductance.
40043	Delta 2	0	65535	R/W	"
40044	Delta 1 MIN	0	65535	R/W	Smallest change in inductance.
40045	Delta 2 MIN	0	65535	R/W	"